

### A UNIQUE AND VERSATILE STRAW SPREADER

Simple and versatile, the Warzée DE500 unroller-spreader allows for the distribution of round bales and spreading of any round or square bale. Thanks to the new "Switch" system, simply place the machine on the ground to lower and raise the spreading rotor, easily switching between distribution and spreading functions.

**RAISED PLATE**  
The raised plate helps to keep the bale and material inside the box and can be adjusted to adapt the straw spreader to each bale, whether round or square.

**Round and square bales**

**SWITCH SYSTEM**  
The "Switch" system allows the user to automatically lower and raise the rotor by placing the machine on the ground.

**Mulching up to 15 meters**

**DEFLECTOR**  
The manually adjustable mechanical deflector allows you to set the mulching distance, from 2 to 15 meters.

**Less dust**

**ROTOR**  
Thanks to the rotor, it's possible to spread any round or square bale. Simply lower and raise it to switch from unrolling to spreading.

**AUTOMATIC HOOKING**  
The hooking between the spike bar and the machine is 100% automatic and requires no manual intervention from the operator. This same spike bar is used to load both round and square bales into the Warzée DE500's box and to drive the machine.

**No electrical functions**

**Distribution on 3 sides**







### LESS DUST

The Warzée DE500 straw spreader is equipped with a circular mulching rotor with teeth. Unlike traditional turbine straw spreaders, this system does not break the straw strands, preserves the quality of the straw, and minimizes dust.

### DISTRIBUTION BELT

Durable, the chain conveyor easily unrolls all types of round bales. Thanks to the bi-directional rotation of the belt, the machine can handle hay and wrapped bales, including wet and deformed bales.

### SWITCH SYSTEM

To avoid unnecessary electrical functions, Warzée has developed the "Switch" system, an automatic hydraulic 3-way valve. This system allows the user to change the position of the rotor, enabling a seamless switch between mulching and distribution functions.

## SPECIFICITY

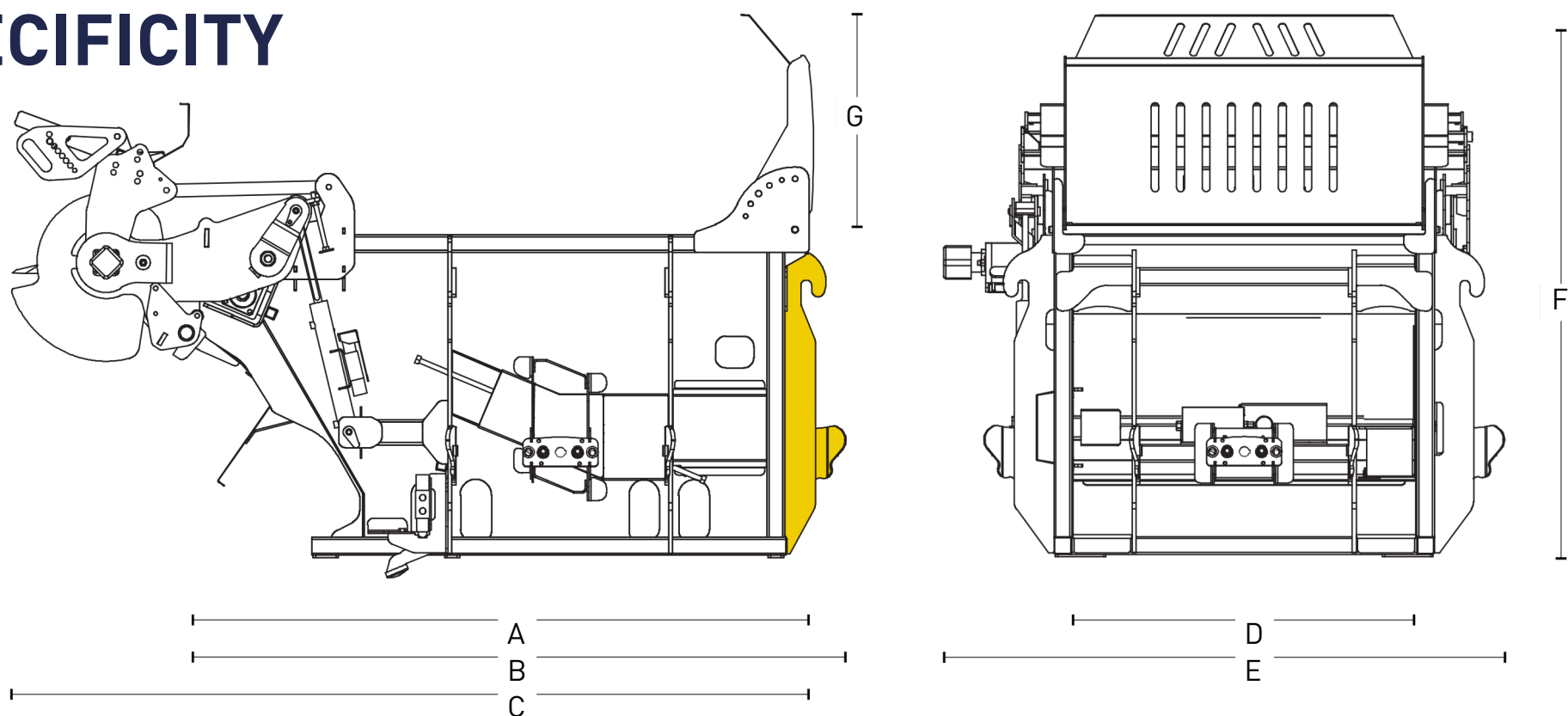

## DIMENSIONS

A	2400 mm
B	2640 mm
C	3400 mm
D	1340 mm
E	2200 mm
F	2400 mm
G	940 mm

## BALES

- ✓ Rounds (distribution + mulching) - Ø 170-200 cm
- ✓ Square (mulching) - max. 120/120, length 250 cm
- ✓ Straw, hay, and wrapped
- ✓ Up to 1500 kg

If the loader generates a return pressure higher than 40 bar, it will be necessary to install a drainage system on both the loader and the machine.

## THIRD SIDE / FRONT (Option)

A third attachment side can be added to the machine. With this option, it is possible to distribute and spread from the front, in addition to the usual two sides.

## WEIGHT

(with spike boots included)

DE500	1500 kg
Third side	100 kg

## LOADERS

Telescopic loaders

## SPECIFICATIONS

Min. 85 L/min. - Max. 200 bar

## OUR LIVESTOCK RANGE

